



BZ 854

Voltage Indicator max. 2000V

For DC usage B+Z Art. Nr. 843

For AC usage B+Z Art. Nr. 921

According to standard EN 50155
Electronic devices in rolling stock



Table of content:

1.	Function / Description	2
2.	Technical data	2
3.	Technical diagram	3
4.	Measures / Mounting	3

Function

The device detects the connected high voltage (AC or DC) on the busbar or other high voltage signals. It signals voltages greater than 50 V via a galvanically isolated switching contact. The maximum high voltage that can be applied is 2000VAC / DC. The built-in type A safety relay with forced contacts signals the voltage applied:

Relay 1 is active when $U_{IN} = >50V \pm 2V$

The reaction / delay time for voltage changes at the high-voltage input is approx. 1 second.

Technical data

Type designation: BZ854

• Standards

The product is manufactured in accordance with the following standards:

ISO 9001:2015
Electronic equipment used on rolling stock: EN50155
Electromagnetic compatibility: EN50121-3-2
Isolation: EN50124-1
Shock and vibration: EN50155/EN61373
Fire protection according to EN 45545

The standards applicable to this product are dependent on the version available at the time of development.

• Operating voltage

Nominal voltage: 36V DC
Tolerance according to railway standard: -30% +25%
Current at 36V max. 50 mA

Protective circuit: Polarity reversal protection diode, overvoltage protection for relay coil.

• Input

Voltage range : 0 to max 2000V AC/DC
Impedance : > 1M Ohm

Measuring range: 50VAC/DC to max. 2000V AC/DC

• Output

Contacts: 1 changeover contact
Relay type: A, according to EN 50205
Max. contact load: ohm = 50V/2A, inductive = 50V/0.8A



B + Z Elektronik AG

Created 21.10.09
Modified: 19.07.10
Index: File: BZ854_e_kd.doc

Seite: 2/5

BZ854
Voltage indicator 2000V max.

• General data

Measures (DxLxH): 120 x 120 x 100 mm
 Max. length : with cables see drawings
 Weight: ca. 1800g (without counter connector)

• Contact load:

Minimum current: 10mA
 Relaiotyp: ST-1
 Current load limit DC: ohm = 50V/1A, inductive = 50V/0.8A

Initial contact resistance, max.		30 mΩ		
Rating (resistive)	Max. switching power	2,000 VA, 150 W		
	Max. switching voltage	380 V AC, 30 V DC		
	Max. switching current	8 A		
HP rating		1/4 HP 125, 250 V AC		
Inrush current capability		51 A (TV-3 equivalence) for 1a1b 35 A (TV-1 equivalence) for 2a		
Expected life (min. operations)	Mechanical (at 180 cpm)	10 ⁷		
	Electrical	8 A 250 V AC (resistive)	10 ⁵	
		5 A 30 V DC (resistive)	2 × 10 ⁵	
		3 A 100 V AC (lamp)	3 × 10 ⁴	—
		1 A 100 V AC (lamp)	—	3 × 10 ⁴

REFERENCE DATA

1. Max. switching power

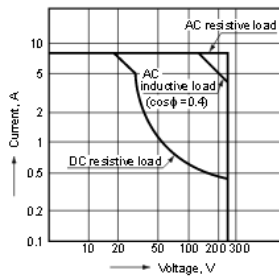

2. Life curve

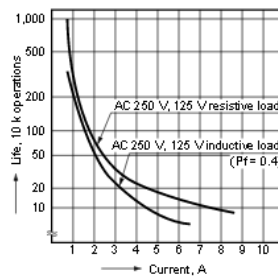

3. Coil temperature rise
 Sample: ST1-DC24V

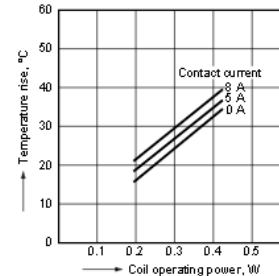

2.3. Other information

• Insulation tests

1. Test = High voltage resistance between high voltage input and DC supply ; Test: 2.5 kV DC
2. Test = Puncture resistance of the device against the mounting surface 5000Vpp AC during 60 Sekunden

• Climatic conditions

Environment temperature : - 40°C...+75°C



B + Z Elektronik AG

Created 21.10.09
 Modified: 19.07.10
 Index: File: BZ854_e_kd.doc

Seite: 3/5

BZ854
 Voltage indicator 2000V max.

- **Enclosure**

Form : standing plastic housing for screw mounting, completely encapsulated.

- **Materials**

Enclosure: Plastic, black, glass reinforced
Compound: Resin
PCB: Epoxy

Labeling: Block diagram and connection details shown on enclosure side

Humidity: up to 96% rF, at 30°C, non condensing
Schutzart: IP 30

- **Mounting**

In any position

Fastening : 2 screws M6

- **Connection**

Connection type: 14-pin row connector WAGO (codeable)
On the front of the device: 2 High-voltage Radox cables 9GKW single-wire rigid 1.5mm², each 2 m long

- **Disposal**

According to local regulations

- **Options (optional)**

Counter connector 14-pin receptable row connector: WAGO



B + Z Elektronik AG

Created 21.10.09
Modified: 19.07.10
Index: File: BZ854_e_kd.doc

Seite: 4/5

BZ854
Voltage indicator 2000V max.

Block diagram

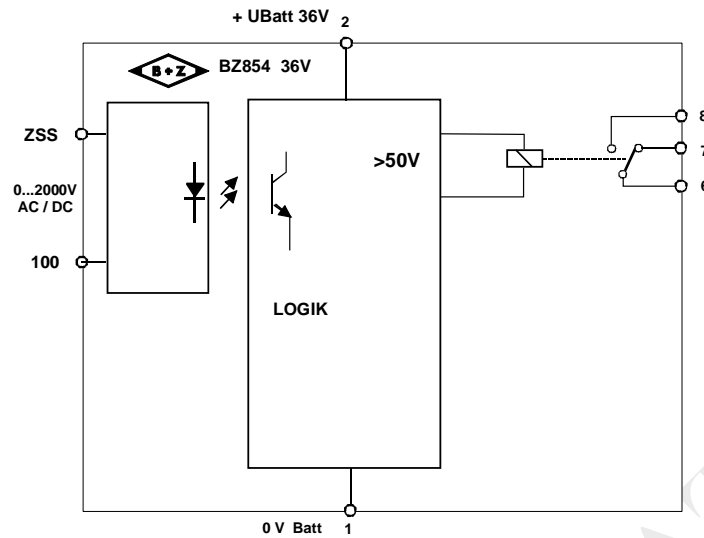

Measures

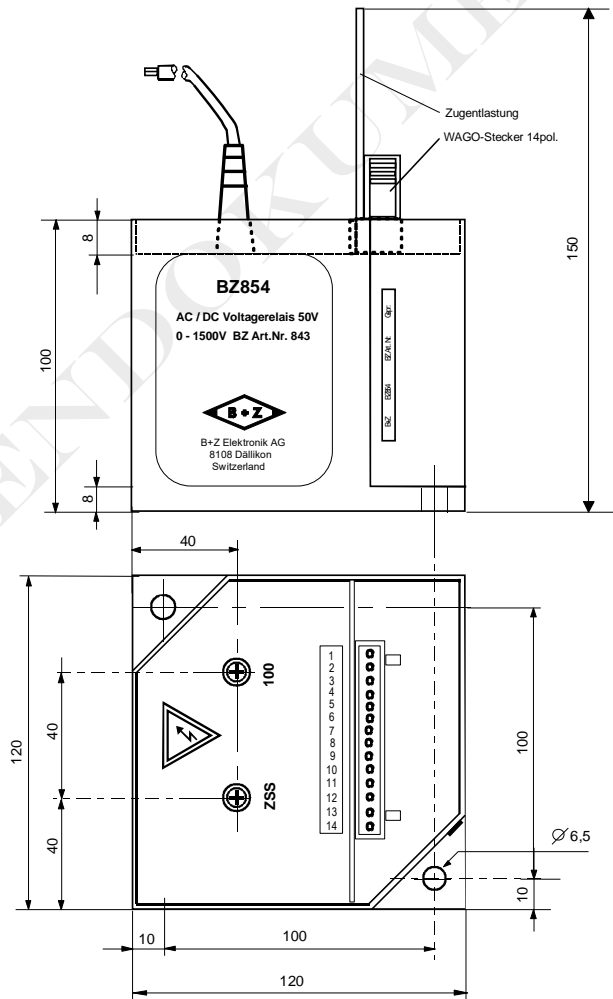

B + Z Elektronik AG

Created 21.10.09
 Modified: 19.07.10
 Index: File: BZ854_e_kd.doc

Geprüft:
 Geprüft:

Seite: 5/5

BZ854
 Voltage indicator 2000V max.